



INSTALLATION AND SERVICING INSTRUCTIONS

7.3L FORD POWERSTROKE BYPASS SYSTEM

KIT FKPWR73

IMPORTANT NOTICE

Please Note – Before Installation

Follow the precautions below for optimal product performance and to reduce the risk of property damage, personal injury, and/or death.

Read All Instructions Before Proceeding

If you are uncomfortable with the instructions or have questions, do not attempt installation. Consult a mechanic or contact our customer service department at 800-341-6516 with any additional questions.

Improper installation of this product may result in damage to the vehicle on which it is installed. For questions regarding installation, contact Frantz customer service at 1-800-341-6516.

Install On Cool Engine

Never work in the engine compartment with the engine running. It is advised that you perform a full oil change with installation of this system.

A. BEFORE YOU BEGIN

1. Confirm all items on the Parts List are included in the system.
2. Ensure you have the required tools for the job.

RECOMMENDED TOOL LIST

- Drill
- 7/32" Drill bit for mounting screws
- 3/8" Socket and wrench for mounting bolts
- 3/8" Wrench for mounting screws
- 7/16" Wrench for male hose fitting
- Utility knife to cut hose and hose covering
- Common screw driver for clamps

PARTS LIST

7.3L Ford Powerstroke Frantz Filter Kit (FKPWR73)

Item	Description	Qty.	Part No.
1.	Mounting Screws with washers	3	FSCR
2.	Base Gasket	1	KBGA
3.	Black Knob	1	KBLK
4.	V-Band Clamp	1	KVCLAMP
5.	Mounting Bracket	1	KMOU
6.	Cellulose Filter Media	1	FFMD-SP
7.	Polished Canister w/Decal	1	KCANP
8.	Pull Ring	1	KPUL
9.	Filter Base	1	KBAS
10.	5/16 SS Nut	2	FNUT516
11.	5/16 x 3/4 SS Bolt	2	FBOLT
12.	5/16 SS Lock Washer	2	FLW516
13.	8' Hose	1	FHOS

Parts List (Cont.)

Item	Description	Qty.	Part No.
14.	8' Hose Covering	1	FHOS-COV
15.	Male Hose Fittings (1/4" Hose Barb)	4	FMAL
16.	1/2" Hose Clamps	4	FOET
17.	90° Brass Elbows	2	FELB90
18.	Spare Gasket	2	KBGA
19.	Thread Seal Package	2	FTHR
20.	3/8" to 1/8" Female Bushing	1	FBUS38
21.	45° Brass Elbows	2	FELB45

Note: Be sure to use thread sealer at all connections. This is most important for connections with dissimilar metals (i.e. brass to aluminum).

B. INSTALLATION INSTRUCTIONS

(some parts for kit may be preinstalled)

MAKE SURE YOU USE THREAD SEAL (FTHR) ON THE THREADS.

1. Locate a good mounting point for the filter. Mount the filter in a place that the hoses will be easy to reach and will not kink. You need enough room to easily separate the canister from the base to replace the filter media. Your kit comes with (3) screws (FSCR) that attach the mounting bracket (KMOU) to the surface you choose. Drill hole with 7/32" drill bit. Use mounting bracket (KMOU) for template for hole layout. The filter base (KBAS) will attach to the bracket with the (2) Nut, bolt, and lock washer combos (FNUT516, FBOLT, FLW516) found in your hardware bag.
2. Your 7.3 has easy access ports to hook up your Frantz Oil Filter so long as they are not being used for other auxiliary aftermarket parts. Locate them on either side of the OE spin on filter mount. **(See Photo)** If these ports are already being used, check out the universal instructions for other setup ideas.
3. Remove the plugs and insert (2) hose fittings (FMAL). The port on the left of the OE filter base will be the pressure feed. The return feed will be on the right. Use 3/8" bushing (FBUS38) in return feed, pictured below

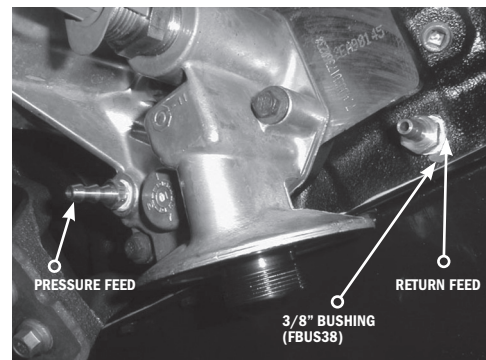

4. Cut hose (FHOS) to length, and route. Be sure to not run hoses close to the Pulleys, Belts, or touching any hot exhaust parts. (Use zip ties to secure hose if necessary - not included.)
5. Install cut hose onto each fitting (FMAL) to the left and right of OE Filter Housing.
6. The pressure feed line from the left port of the oil filter housing will hook up to the fitting on the center of the filter base bottom labeled "IN," and the return line from the right side of oil filter housing will hook up to the fitting on the edge of the filter base labeled "OUT". Insert fittings (FMAL) into "In" and "Out" ports on the base. (Brass 45 degree fittings (FELB45) may be used here if needed for clearance). Slip hose clamps (FOET) over hose leading from pressure feed; push hose onto "In" fitting. Slip hose clamp over hose leading from oil return and push hose onto "Out" fitting. Tighten clamps.
7. Installation is now complete please follow start up procedures (**Section C**).

C. START UP PROCEDURES

1. Check that all fittings and hoses are securely attached, and that the hoses are routed properly.
2. Check engine oil level. Fill to full mark on engine dipstick.
3. With the equipment secured start the engine and immediately check oil pressure. NOTE: Pressure may initially take a moment or two to rise. Let your engine run for a minimum of five minutes after installation. This allows your new Frantz Filter to begin absorbing oil in the media and fill the hoses.

Caution: carefully check for leaks at fittings, hoses and mount. If leaks are observed, **STOP ENGINE IMMEDIATELY**, repair leaks and continue.

4. After engine has been ran for a minimum of five minutes, shut off and re-check engine oil level. Fill as necessary.
5. Install black hose covering (FHOS-COV) on hoses.
6. Record vehicle mileage/operating hours and date of installation.

D. PERIODIC MAINTENANCE

1. Inspect the fittings and hoses. Check for leaks, hose deterioration and cuts. Repair and/or replace as necessary. **(At minimum at every oil change or 3000 miles whichever occurs first)**
2. Filter media should be changed when engine oil is up to operating temperature and the filter housing is not warm. **(This indicates oil is no longer flowing through the filter)**

E. CHANGING THE FILTER ELEMENT

Caution: Engine should be cold when changing the filter element.

To change the bypass filter element:

1. Ensure the engine is off and use caution as the engine, oil and filter may be hot and can result in personal injury. **(Let engine cool down, or start with cold engine.)**
2. Loosen the black knob on the clamp and remove the clamp from the unit.
3. Pull filter housing off the filter base.
4. Grab pull ring to remove old filter from the canister, dispose of properly.
5. Clean out the Canister with a lint free rag and inspect filter base gasket, replace if any cuts or imperfections are found. Make sure gasket is sitting correctly in the receiver groove and coat with clean motor oil.
6. Install the new filter media with pull ring in the filter. Install canister back on filter base.
7. Tighten Clamp using black knob.
8. Install V-Band Clamp on base. Check oil level and refill as needed.
9. Start the engine and check for leaks. (Run engine a minimum of 5 minutes)
10. Stop engine.
11. Check oil level and refill as needed.
12. Record date of installatin and miles/hours of the unit.

THE FRANTZ WARRANTY AND GUARANTEE

The Frantz Warranty

Frantz will replace any part or component that proves defective within 90 days. It will be replaced free of charge (no cost for labor) within that period.

NOTE: If an oil line fails, or an oil leak develops in the Frantz (either through failure of a part, sabotage, incorrect installation, or faulty servicing of the unit), and the engine loses its oil supply, Frantz disclaims any responsibility for damage to the engine should it be operated without proper lubrication.

Every vehicle has either a pressure gauge or warning light to indicate that oil pressure is not sufficient to lubricate the engine. When this occurs, it is the responsibility of the driver to stop the vehicle, investigate the problem, and take whatever remedial action is necessary.









The Frantz Guarantee

Frantz unconditionally states that if the Frantz has been installed and serviced in accordance with the manufacturer's instructions, the filter will keep the oil in your vehicle analytically clean. If it fails to do so, the purchase price of the unit will be refunded by the manufacturer, provided the filter, all parts and the original sales receipt are returned to Frantz. (customer responsible for shipping cost back to Manufacturer).

7.3L Ford Powerstroke Bypass System Kit FKPWR73

PARTS IDENTIFICATION





Pages 3 - 5

NAME	SKU	QTY	VISUAL
Mounting Screws with washers	FSCR	3	
Base Gasket	KBGA	1	
Black Knob	KBLK	1	
V-Band Clamp	KVCLAMP	1	
Mounting Bracket	KMOU	1	
Cellulose Filter Media	FFMD-SP	1	
Polished Canister w/Decal	KCANP	1	
Pull Ring	KPUL	1	

7.3L Ford Powerstroke Bypass System Kit FKPWR73

PARTS IDENTIFICATION

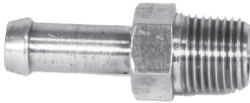

Pages 3 - 5

NAME	SKU	QTY	VISUAL
Filter Base	KBAS	1	
5/16 SS Nut	FNUT516	2	
5/16 x 3/4 SS Bolt	FBOLT	2	
5/16 SS Lock Washer	FLW516	2	
8' Hose	FHOS	1	
8' Hose Covering	FHOS-COV	1	
Male Hose Fittings (1/4" Hose Barb)	FMAL	4	
1/2" Hose Clamps	FOET	4	

7.3L Ford Powerstroke Bypass System Kit FKPWR73

PARTS IDENTIFICATION

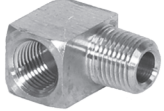
Pages 3 - 5

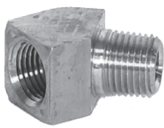
NAME	SKU	QTY	VISUAL
90° Brass Elbows	FELB90	2	
Spare Gasket	KGBA	2	
Threas Seal Package	FTHR	2	
3/8" to 1/8" Female Bushing	FBUS38	1	
45° Brass Elbows	FELB45	2	

Engine Fittings and Adaptors

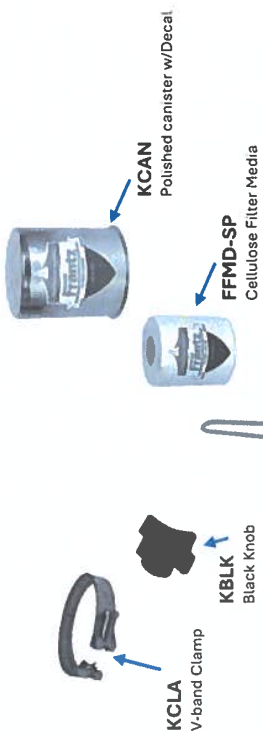

Filter Base Adaptors

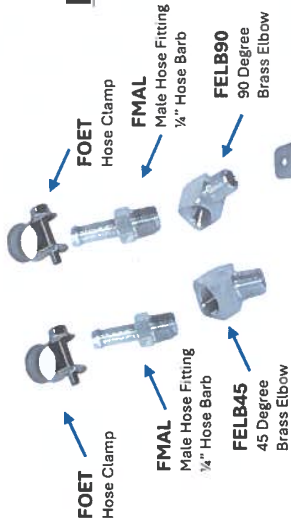

Engine Fittings and Adaptors

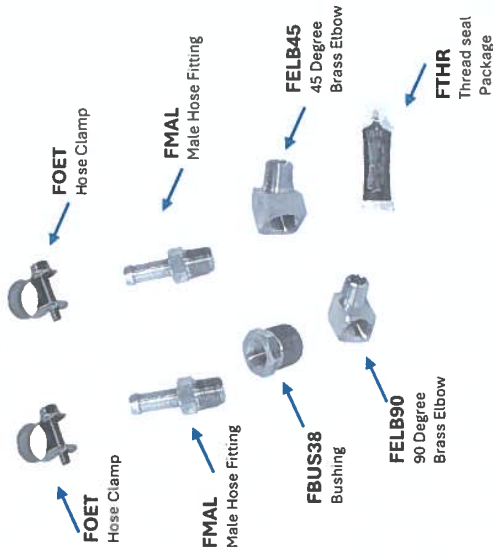

Rubber Hose and Hose Covering



Mounting Bracket and Hardware

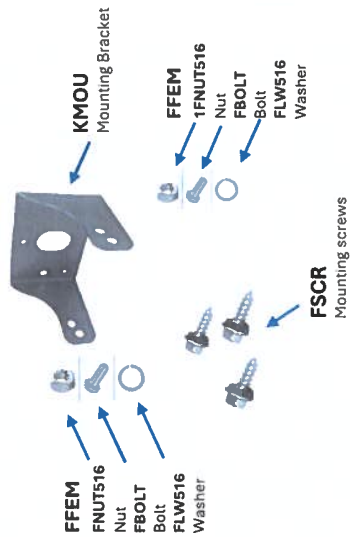

Spare Base Gaskets

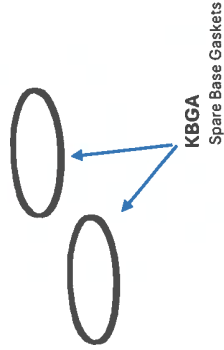

FKPWR73

7.3L Ford Powerstroke Kit